

Kol. Opis**1 SOLOLIFT2 CWC-3**

Paznja! Slika proizvoda se može razlikovati od stvarnog proizvoda

Proizvodni broj: [97775316](#)

Sololift2 CWC-3 is a small, compact automatic lifting station suitable for pumping of wastewater off places in private dwellings where wastewater cannot be led directly to the sewer by means of a natural downward slope.

Sololift2 CWC-3 is typically used for:

- wall-hung toilets, cabinet showers and washbasins in basements below sewer level, in connection with the renovation or modernisation of existing buildings, where the location may be remote from the main soil pipe so that a natural slope cannot be established.

Extremely low switching levels for lowest construction heights, advantageously in case of connection of a shower receptor.

Sololift2 CWC-3 is suitable for installation in a hollow space behind a wall-hung toilet.

This lifting station is only suitable for pumping wastewater from a cabinet shower and a washbasin as well as sewage water from a toilet containing toilet paper and faeces.

The pumping of liquids containing other material may cause faults and limit the scope of our guarantee.

The compact lifting station is equipped with

- Cable with or without plug (see technical data)
- Horizontal or vertical fastening possibility of discharge hose connector with several adaptors for pipes with Ø22-40mm
- integrated non return valve
- Dry and high performance motor unit incl. thermal protection, pressure switch and controller
- DN100 toilet connection hose
- Flexible connectors for inlet (adjustable in height) of pipes Ø36 or 40
- Slot for an alarm board with buzzer (accessory)
- Manual anti clogging function and separate drain connection for service
- Venting valve with overflow protection
- Uplift fixation clips

Design according to EN12050-3 and production inspection by external institute with unique features focused on quick installation, long lasting operation and easy clean service.

Tečnost:

Dizana tečnost: bilo koja viskozna tečnost

Maximum liquid temperature: 323 K

Gustina: 998.2 kg/m³

Tehnički:

Saglasnosti na natpisnoj pločici: CE,TR,VDEEMV,VDE,MORO

Tolerancija krive: ISO9906:2012 3B

Materijali:

Rezervoar: Plastika

Ugradnja:

Ulaz pumpe: 32/36/40, 36/40/50, DN 100

Izlaz pumpe: 22/25/28/32/36/40

Broj elektroda: 3X0,75MM2

Elektro podaci:

Kol. Opis

Potrebna snaga - P1:	620 W
Frekvencija struje:	50 Hz
Potrebni napon:	1 x 220-240 V
Nazivna struja:	3 A
Cos fi - faktor snage:	0.92
Nazivna brzina:	2800 rpm
Klasa zaštite (IEC 34-5):	IP44
Klasa izolacije (IEC 85):	F
Dužina kabla:	1.2 m
Tip kabla:	H05VV-F-3G
Tip kablovskog utikača:	SCHUKO

Ostali:

Neto masa:	8.09 kg
Bruto masa:	9.69 kg
Danski VVS Br.:	614364632
Swedish RSK No.:	5885483
Finnish LVI No.:	4965314
Norwegian NRF no.:	9045712
Country of origin:	RS
Custom tariff no.:	8413708190

97775316 SOLOLIFT2 CWC-3 50 Hz

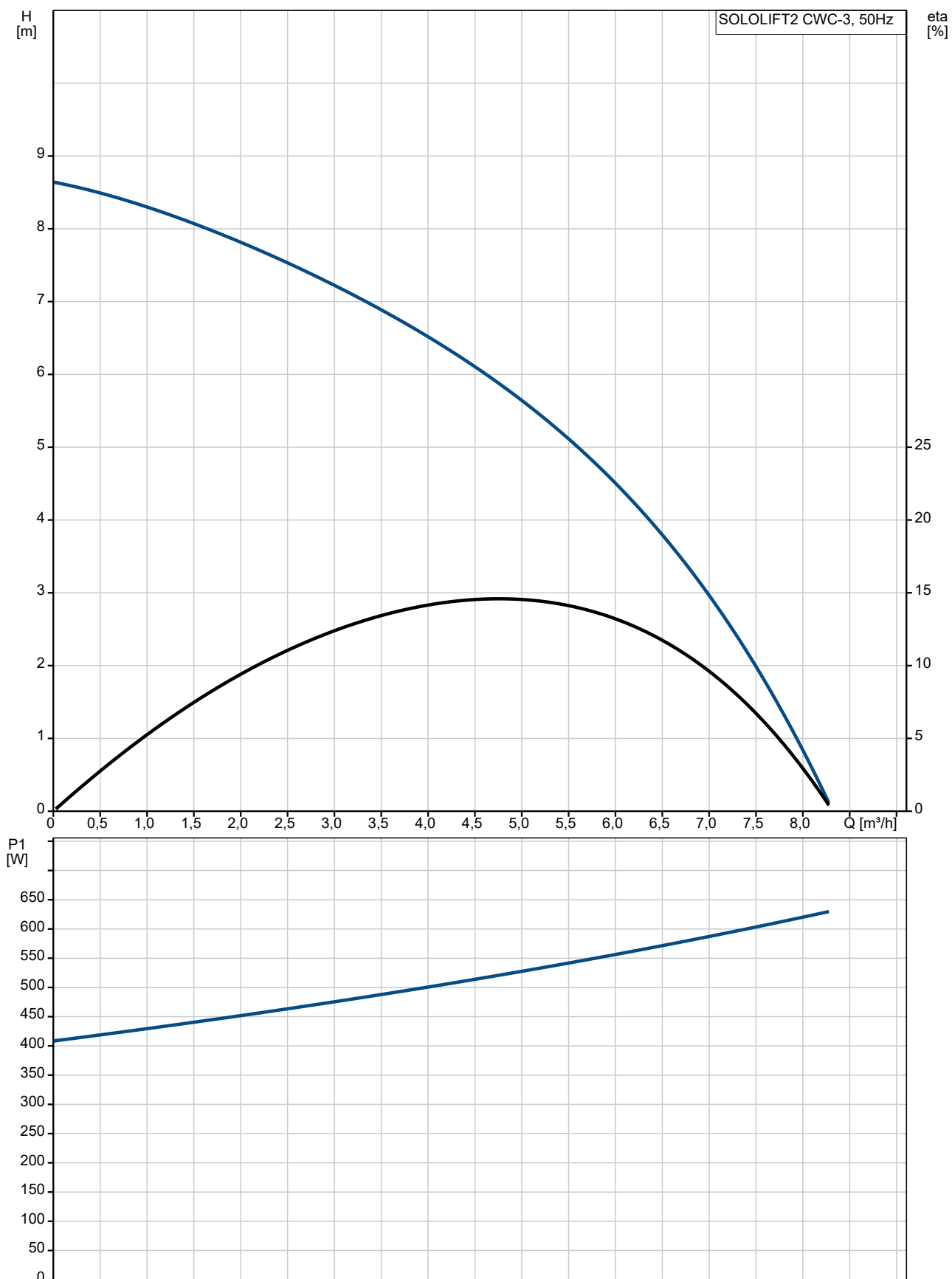

Opis	Vrednost
Opšte informacije:	
Ime proizvoda::	SOLOLIFT2 CWC-3
Šifra proizvoda:	97775316
EAN broj::	5710624187258
Cena:	€ 522.07
Tehnički:	
Visina max.:	8.5 m
Saglasnosti na natpisnoj pločici:	CE,TR,VDEEMV,VDE,MORO
Tolerancija krive:	ISO9906:2012 3B
Materijali:	
Rezervoar:	Plastika
Ugradnja:	
Ulaz pumpe:	32/36/40, 36/40/50, DN 100
Izlaz pumpe:	22/25/28/32/36/40
Broj elektroda:	3X0,75MM2
Tečnost:	
Dizana tečnost:	bilo koja viskozna tečnost
Maximum liquid temperature:	323 K
Gustina:	998.2 kg/m ³
Elektro podaci:	
Potrebna snaga - P1:	620 W
Frekvencija struje:	50 Hz
Potrebni napon:	1 x 220-240 V
Nazivna struja:	3 A
Cos fi - faktor snage:	0.92
Nazivna brzina:	2800 rpm
Klasa zaštite (IEC 34-5):	IP44
Klasa izolacije (IEC 85):	F
Termička zaštita:	THERMIK S06-150-05
Dužina kablova:	1.2 m
Tip kablova:	H05VV-F-3G
Tip kablovskog utikača:	SCHUKO
Ostali:	
Neto masa:	8.09 kg
Bruto masa:	9.69 kg
Pregled tipova:	Internacionalni
Danski VVS Br.:	614364632
Swedish RSK No.:	5885483
Finnish LVI No.:	4965314
Norwegian NRF no.:	9045712
Country of origin:	RS
Custom tariff no.:	8413708190

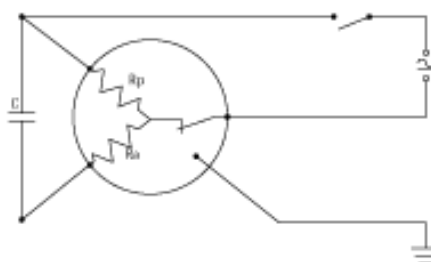
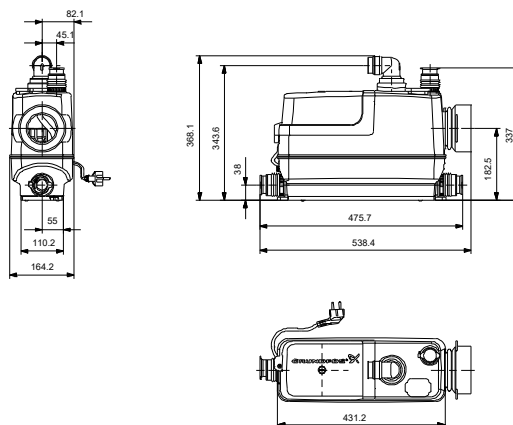
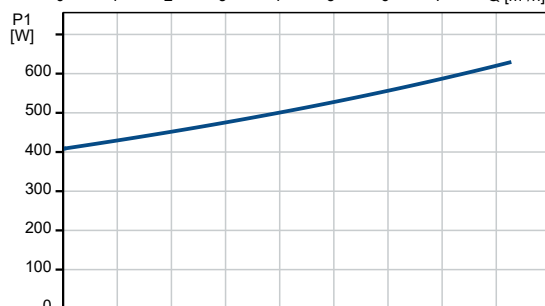
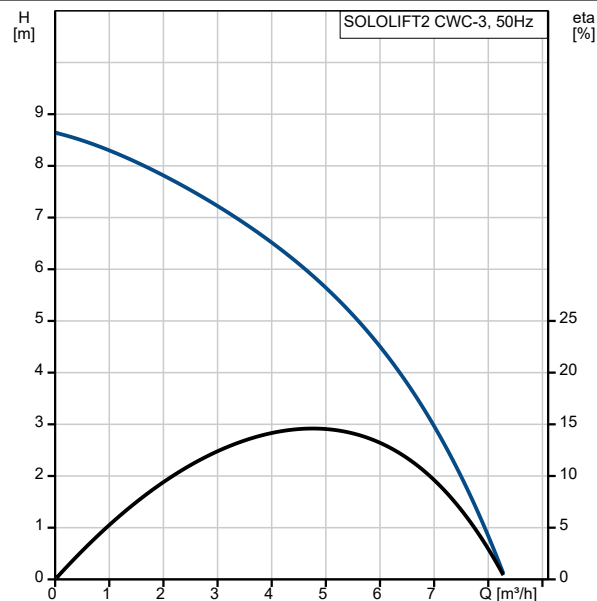

97775316 SOLOLIFT2 CWC-3 50 Hz

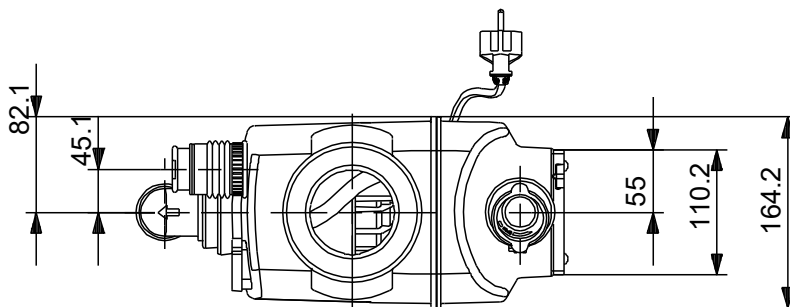
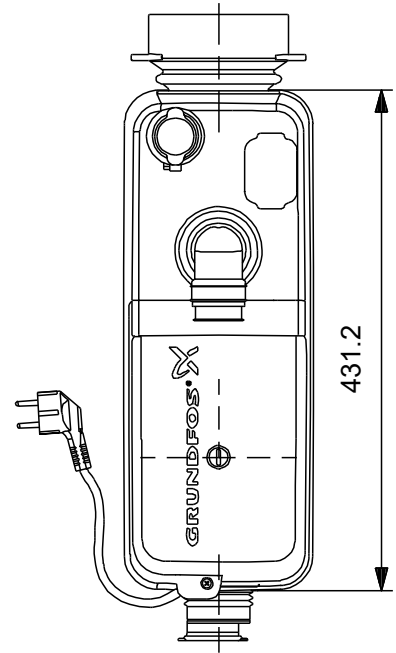
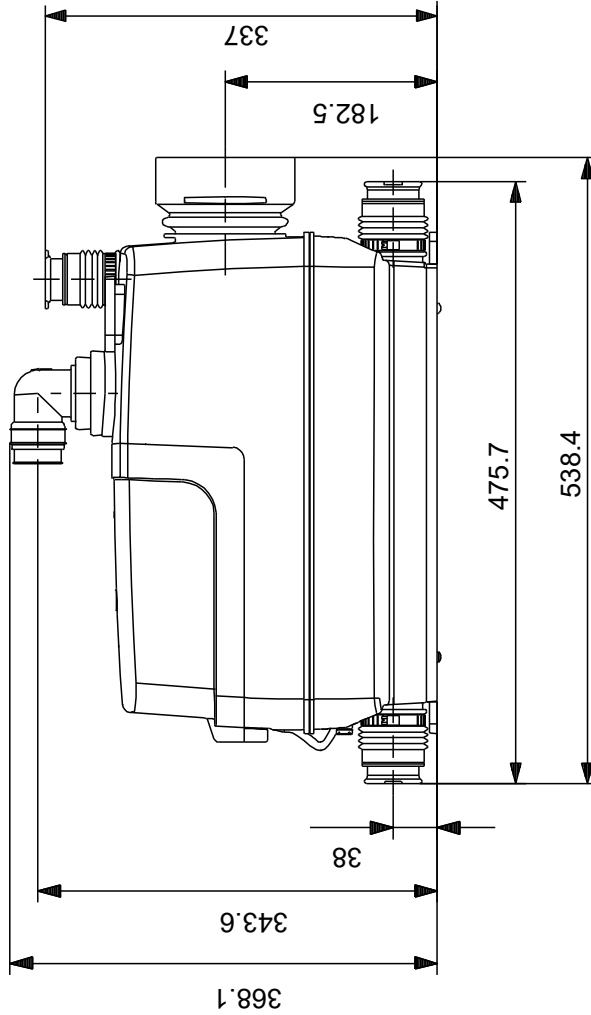

Napomena! Sve jedinice su u [mm] ukoliko drugačije nije navedeno.
Upozorenje: Ovaj pojednostavljeni dimenzioni crtež ne pokazuje sve detalje.

97775316 SOLOLIFT2 CWC-3 50 Hz

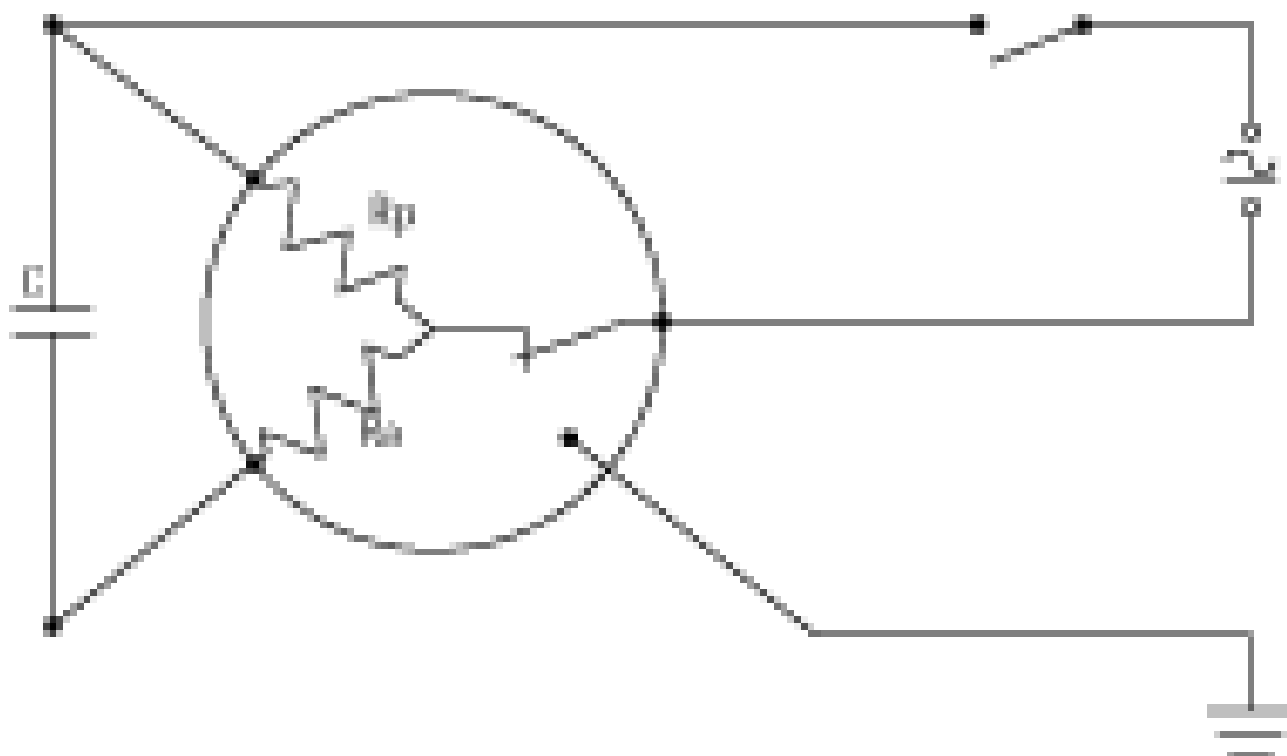

Pažnja! Sve jedinice su u [mm] ukoliko nije rečeno drugačije.